

On Consideration for Fracture Toughness Evaluation of Mode II

Ken-ich HASHIMOTO*

Abstract

The evaluation of fracture toughness for Mode II and Mode III is very important when we consider the extension of cracks under compressive loading. The standard testing method for fracture toughness evaluation is already proposed and usually carried out by Mode I testing. However, the evaluation of fracture toughness for Mode II or Mode III is independent of one for Mode I. Therefore, we have to consider on the evaluation method in some form for Mode II and Mode III.

In this study, fracture toughness K_{IIc} is estimated by three kinds of testing methods using the model that can evaluate a stress intensity factor K_{II} . The acrylic resin specimens that show a linear behavior is used for the experiment, and K_{IIc} is evaluated by using the maximum load. Then, the difference between K_{IIc} and previously reported K_{IC} for same material, is considered. The error over each testing method is investigated, and the strong and weak point for each procedure is discussed.

Key Words: fracture toughness, K_{IIc} , testing method, acrylic resin, testing accuracy

1. Introduction

Fracture mechanics is primarily used to prevent and predict catastrophic failure of structure of man-made materials such as metals, plastics, and ceramics. Historically fracture mechanics is a development of the strength approach of materials, in which the stress in a structure is compared with some material strength value in order to decide whether failure will occur or not. The basic material parameter in fracture mechanics is called the fracture toughness.

The fracture toughness describes the critical stress concentration at a crack tip necessary to initiate crack growth. The theory provides a means of determining the stress concentrations at a crack tip in a material containing flaws or pre-existed cracks in term of a stress intensity factor. The stress intensity factor is a parameter dependent on the structure geometry, applied stress and initial crack length and has dimensions of stress \times (length)^{1/2}, for example MPam^{1/2}. Based on the loading type that a material is subjected to, there are three basic crack deformation mode, Mode I (opening), Mode II (in-plane shear), and Mode III (out-of-plane shear).

Tensile fractures are frequently observed in nature and the measurement of the Mode I fracture toughness has been standardized.¹⁾ However, the crack deformation modes is

dominated by Mode II and Mode III in the materials under compressive loading. Therefore, the evaluation of Mode II and Mode III fracture toughness is important.

The existence of Mode II fracturing in rock is regarded as important, because most of rocks exist in the compressive stress field. However, the number of reports that deal with the Mode II fracture toughness is small. There are some special methods in the method for testing the Mode II fracture toughness reported until now^{2),3)}. However, describing in relation with the testing method, all methods are very complex. Therefore, to find out a good method is significant.

The purpose of this study is to evaluate Mode II fracture toughness of materials, K_{IIc} . Three kinds of testing methods are used for the evaluation of Mode II fracture toughness of materials, K_{IIc} . The acrylic resin specimens that show a linear behavior are used as the homogeneous material. As the result, the difference between K_{IIc} and previously reported K_{IC} for same material, is considered and the dispersions over each the experimental results are investigated and the validity of each testing method is discussed.

2. Testing Methods for Fracture Toughness Evaluation of Mode II

Three testing methods are used to evaluate

* Department of Civil Engineering and Architecture

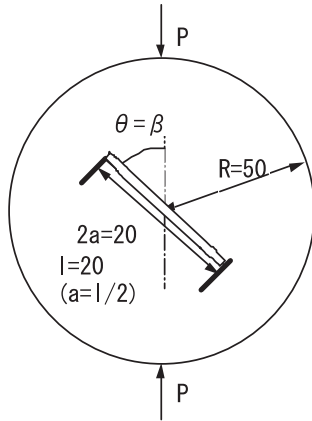

Fig. 1 Sample geometry and loading method for CBD test

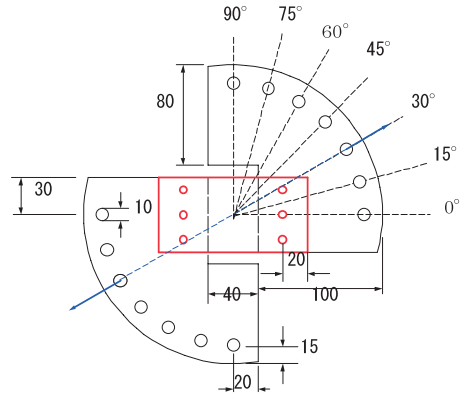

Fig. 3 Loading device for RT test

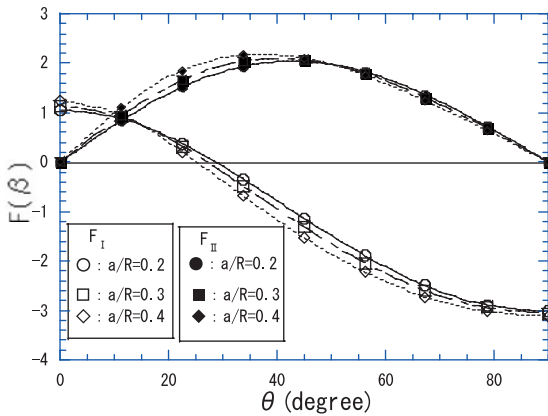

Fig.2 F_I and F_{II} for stress intensity factor in CBD test

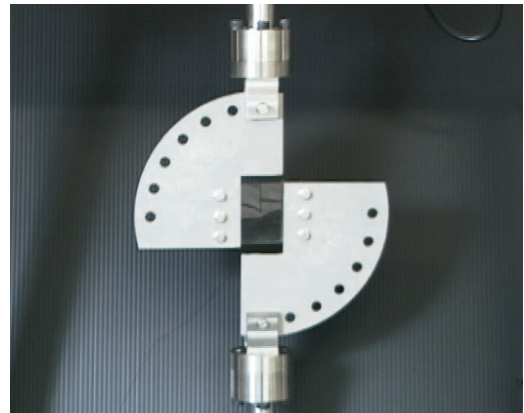

Fig. 4 Experimental view of RT test

Mode II fracture toughness. In these methods, one method is new type method for measuring only Mode II fracture toughness. Other two methods are already known methods and ones for generally evaluating the mixed mode fracture toughness.

(1) Center slant cracked circular plate subjected to compression load⁴⁾ (CBD)

Summary of CBD test for the mixed mode fracture toughness is shown in **Fig. 1**. Stress intensity factors are evaluated by the following.

$$K_I = F_I(\beta) \frac{P}{Rt} \sqrt{\frac{a}{\pi}} \quad (1)$$

$$K_{II} = F_{II}(\beta) \frac{P}{Rt} \sqrt{\frac{a}{\pi}} \quad (2)$$

where F_I and F_{II} are given by the values in

Fig. 2 and t is sample thickness. P , R , a , and β are loading value, sample radius, a half of crack length and loading angle respectively and shown in **Fig. 1**. Pure Mode II is realized by using $\theta = 28.5$ degree.

(2) Single edge cracked test for mixed mode loading device⁵⁾ (Richard type test, RT)

Loading device and test view for RT test are shown in **Fig. 3** and **Fig. 4**. This test is one for measuring the mixed mode fracture toughness too. Stress intensity factors are evaluated by the following.

$$K_I = \frac{P\sqrt{\pi a}}{Wt} \cdot \frac{\cos \alpha}{1 - \left(\frac{a}{W}\right)} \sqrt{\frac{0.26 + 2.56\left(\frac{a}{W-a}\right)}{1 + 0.55\left(\frac{a}{W-a}\right) - 0.08\left(\frac{a}{W-a}\right)^2}} \quad (3)$$

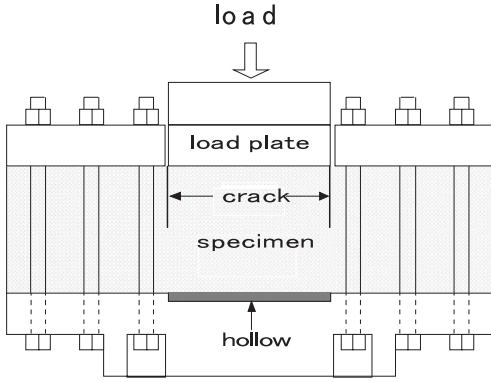

Fig. 5 Summary of DCPS test

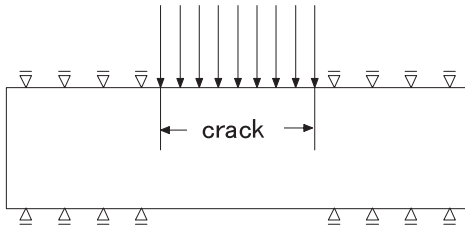

Fig. 6 Loading condition of DCPS test

$$K_{II} = \frac{P\sqrt{\pi a}}{Wt} \cdot \frac{\sin\alpha}{1 - \left(\frac{a}{W}\right)} \sqrt{\frac{-0.23 + 1.40\left(\frac{a}{W-a}\right)}{1 - 0.67\left(\frac{a}{W-a}\right) + 2.08\left(\frac{a}{W-a}\right)^2}} \quad (4)$$

where P, W, a, t, and α are loading value, sample width, crack length, sample thickness and loading angle respectively in Fig. 3. Pure Mode II is given by taking 90 degree for the angle in Fig. 3. Loading condition for the pure Mode II is shown in Fig. 4.

(3) Double cracks punch-through shear (DCPS; Fig. 5, Fig. 6)

DCPS test is new type test for the Mode II fracture toughness evaluation. This test has the pure Mode II loading system. However, the exact stress intensity factors didn't obtain analytically. Therefore, numerical analysis using the finite element method is conducted in this study. After the energy release rate is obtained by using the E-integral method⁶⁾, stress intensity factor is calculated by the follow relationship between energy release rate \mathcal{G} ant stress intensity

Table 1 Material property of acryl resin.

Tensile strength	74.5 MPa
Bending strength	117.7 MPa
Compressive strength	123.6 MPa
Shearing strength	61.8 MPa
Young's modulus	2.94 GPa

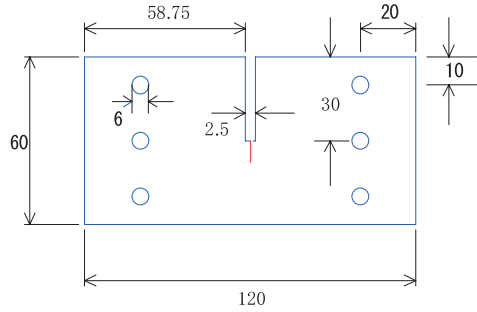

Fig. 7 Specimen geometry for RT test(mm)

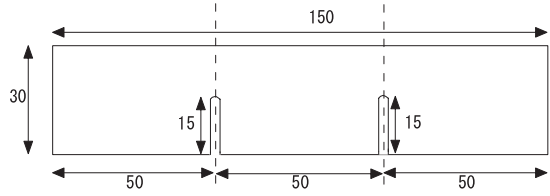

Fig. 8 Specimen geometry of DCPS test(mm)

factor K.

$$\mathcal{G}_{II} = \frac{K_{II}^2}{E'}$$

where $E' = \begin{cases} E & (\text{plane stress}) \\ E/(1-\nu^2) & (\text{plane strain}) \end{cases}$

3. Experiment

The acryl resin (poly-methyl methacrylate : PMMA) which shows the deformation and failure behavior near a linear elastic body was used as a material of experiment specimens. The material property of acryl resin is shown in Table 1. Then, fracture toughness K_{IC} is about $1.3 MPa\sqrt{m}^7)$.

Table 2 Experiment results contained experiment error for CBD test

Specimen Name	F_I	F_{II}	Fracture Load (kN)	Fracture Toughness $K_{IIIC}(MPa\sqrt{m})$	Average Fracture Toughness	Error (%)
28.5-1	0.0078	1.7922	8.330	1.685	1.592 ± 0.083 $MPa\sqrt{m}$	5.2
28.5-2			7.742	1.566		
28.5-3			7.546	1.526		

Table 3 Experiment results contained experiment error for RT test

Specimen Name	Fracture Load (kN)	Fracture Toughness $K_{IIIC}(MPa\sqrt{m})$	Average Fracture Toughness	Error (%)
90-1	0.4304	1.534	1.518 ± 0.101 $MPa\sqrt{m}$	6.7
90-2	0.4513	1.609		
90-3	0.4104	1.410		

Table 4 Experiment results contained experiment error for DCPS test

Specimen Name	Specimen Length (mm)	Specimen Width (mm)	Specimen Thickness (mm)	Notch Length (mm)	Fracture Load (kN)	Fracture Toughness $K_{IIIC}(MPa\sqrt{m})$	Average Fracture Toughness	Error (%)
II-1	150.05	30.00	30.01	14.8	29.17	2.28	1.84 ± 0.29 $MPa\sqrt{m}$	15.8
II-2	150.20	30.02	30.08	14.9	21.40	1.68		
II-3	150.09	30.01	30.01	14.9	25.14	1.97		
II-4	150.13	30.06	30.05	14.8	21.37	1.68		
II-5	150.00	30.03	30.06	14.9	20.10	1.57		

In CBD test, three specimens are prepared and these have notch length of $2a=20\text{mm}$, specimen radius of $R=50\text{mm}$, and specimen thickness of $t=10\text{mm}$ respectively as shown in **Fig. 1**. Three specimens are prepared for RT test. Sample geometry is shown in **Fig. 7**. Specimen is a plate of $60\text{mm} \times 120\text{mm}$ with crack of length $a=30\text{mm}$ and thickness of $t=2\text{mm}$. Five pieces of specimens are used in DCPS test. Sample is a rectangular solid of $30\text{mm} \times 30\text{mm} \times 150\text{mm}$ with two cracks of length $a=15\text{mm}$. Although all specimens are made by machining progress, the notch tip is processed by hand with the cutter knife.

In these experiments, two electro-hydraulic fatigue testing machines, whose capacities for static loading are 15kN and 450kN, is used. In all tests, the average stress intensity factor rate during the test shall be not less than about $0.002MPa\sqrt{m}$, so that failure occurs within about 10 min of initial

load application.

4. Conclusion and Discussion

Fracture toughness K_{IIIC} values obtained in CBD test are shown in **Table 2** and standard deviation and the values that divide standard deviation by average value as the error are also respectively shown in this table for the each specimen name. K_{IIIC} values show the values within the range of from 1.526 to $1.685MPa\sqrt{m}$. Experimental error is 5.2% and high experimental accuracy is obtained in CBD test.

In **Table 3**, the experimental results for RT test are shown. Fracture toughness values are distributed in the range from 1.410 to $1.534MPa\sqrt{m}$. In the same tendency as CBD test, experimental accuracy is high.

DCPS test indicates the different tendency compared with other two tests. That is, fracture toughness K_{IIIC} values are distributed widely in the range from 1.57 to 2.28 . Experimental

Table 5 K_{IIc}/K_{IC} for various material

Material	K_{IIc}/K_{IC}	Researcher
4340steel	1.09	R.C.Shah
0.44% carbon steel	0.83	T.Yokobori et al
Graphite	1.09~1.16	H.Awaji and S.Sato
Plaster	1.14	
Marble	1.13	
PMMA	0.93	H.A.Richard
Hardwood type fiberboard	0.81	K.Sato
softwood type fiberboard	0.80	
DuPont Corian	0.86	

accuracy is also bad and experimental error indicates 15.8%. Moreover, large fracture toughness values are obtained in this test compared with fracture toughness values in other two tests. Average fracture toughness is $1.84 MPa\sqrt{m}$.

Author has researched for K_{IC} of the same material (PMMA) in detail⁷⁾. In its report, an acryl resin that shows a linear behavior is also used for material, the specimens whose size differs are prepared, and six kinds of fracture toughness testing methods have been tried. As a result, fracture toughness K_{IC} values are distributed widely from 0.990 to 1.959. However it is estimated by these experiments that inherent fracture toughness K_{IC} is about $1.3 MPa\sqrt{m}$. In this experiments, the average Mode II fracture toughness K_{IIc} was $1.68 MPa\sqrt{m}$. The ratio K_{IIc}/K_{IC} became 1.29. In here, K_{IIc}/K_{IC} for various material is picked up in **Table 5**. The value 1.29 is larger than the ratios in other reports. For this

reason, the following are the conceivable factor. That is to say, K_{IIc} is largely estimated by large thickness in DCPS test. This tendency is shown in the evaluation of K_{IC} . But, many specimens with thin thickness are contained in the previous report. At all events, it is guessed that the difference between K_{IIc} and K_{IC} is not so large for all materials.

New type Mode II fracture toughness test, DCPS test, is effective for the preparation of specimens. However, it is very difficult to apply a uniform load. Moreover, we need to find out the a simple and easy expression for K_{II} .

References

- 1) Annual Book of ASTM Standards: Standard Test Method for Plane-Strain Fracture Toughness of Materials, E399-90, Part 10 (1990)
- 2) Ingraffea A. R. : Mixed-mode fracture initiation in Indian limestone and Westerly granite. In: Einstein, H., editor, Proceedings of the 22nd US Symposium on Rock Mechanics. Cambridge Mass., pp.199-204 (1981)
- 3) Backers T, Stephansson O. and Rybacki E. : Rock fracture toughness testing in Mode II – punch-through shear test, Int. J. Rock. Mech. Min. Sci., Vol. 39, pp.755-769(2002).
- 4) Atkinson, C., Smelser, R. E. and Sanchez, J. : Combined Mode Fracture via the Cracked Brazilian Disk Test, Int. Frac. Vol. 18, No.4, pp.279-182 (1982)
- 5) Richard, H. A. and Benitz, K. : A Loading Device for the Creation of Mixed Mode in Fracture Mechanics, Int. J. Frac., Vol. 22, pp.R55-58 (1983)
- 6) Yatomi C. and Hashimoto K. : On the Energy Release Rate by the Path-independent E-integral and J-integral for Quasi-static Crack Growth, Theoretical Studies on Fracture Mechanics in Japan, pp.87-98(1998)
- 7) Hashimoto K. : Consideration on Evaluation of Fracture Toughness and Testing Methods, Research Reports of The Tokuyama College of Technology, No.27, pp7-12(2003)
- 8) Sato K. : Fracture of Building Materials under Mixed Modes I and II, J. Soci. Mate. Sci., Vol 39, No. 447, pp.1676-1681(1989).

(Received September 5, 2007)

